

DAVEY



DAVEY CrystalClear[®]ER SERIES

Model Numbers:
DCC135, DCC180, DCC225, DCC270

GUARANTEE
10 YEARS Tank
1 YEAR
Components

APPLICATIONS

Ideal for in-ground and above ground pools.
Suitable for salt, mineral salt and fresh water pools.
Models suitable for pools up to 180,000 litres.

ECONOMIC HIGH PERFORMANCE CARTRIDGE FILTER

FEATURES & BENEFITS

- Provides crystal clear water with minimal maintenance.
- Less water used, no backwashing needed. Ideal for applications where backwashing may not be practical or areas where water may be scarce.
- Tank constructed from high impact polypropylene as a solid one-piece mould for a non-corrosive long life.
- Low profile designed with easy access to the filter cartridge for removal, cleaning and installation.
- A quality pressure gauge makes it easy to see when element cleaning is required.
- A manual air bleed enables the filter to be de-pressurised before opening for cleaning.
- Filter cartridges are fabricated from heavy duty, reusable polyester fabric with wide and deep pleats for better filter efficiency, easy cleaning and longer cartridge life.
- Replacement filter elements available
- 50mm quick connect barrel unions supplied for simple installation
- Maximum flow rate 510 lpm
- Maximum working pressure 250 kPa

DAVEY CrystalClear[®]ER SERIES



Air bleed purges trapped air during filtration

Hand operated lid lock ring, allowing simple cartridge removal and replacement

Tough heavy duty polyester filter fabric with wide and deep pleat for better filter efficiency, easy cleaning and longer cartridge life

Large spaces between pleats for easy cleaning and long filtration cycles

Solid one piece moulded polymer tank seamless and no joint for superior quality

| TECHNICAL SPECIFICATIONS | | | | |
|---|----------|----------|----------|----------|
| Model | DCC135 | DCC180 | DCC225 | DCC270 |
| Filtration area (m ² / ft ²) | 12.5/135 | 16.7/180 | 20.9/225 | 25.1/270 |
| Maximum flow rate (lpm)* | 381 | 450 | 480 | 510 |
| 6 hour turnover (litres) | 133,000 | 157,000 | 167,500 | 183,600 |

* Based on the residential flow rate and 50mm pipe

| OPERATING LIMITS | |
|----------------------------|--------|
| Maximum water temperature | 50°C |
| Maximum operating pressure | 250kPa |
| Maximum Pressure Drop | 20kPa |

| REPLACEMENT FILTER | | | |
|---------------------------|------------------------------------|---|---------------------|
| Model | Model Number Replacement Cartridge | Description | Nominal Filter Size |
| DCC135 | DCE1039 | CrystalClear ER Cartridge Element 135ft | 135 |
| DCC180 | DCE1038 | CrystalClear ER Cartridge Element 180ft | 180 |
| DCC225 | DCE1040 | CrystalClear ER Cartridge Element 225ft | 225 |
| DCC270 (twin filter unit) | DCE1041 | CrystalClear ER Cartridge Element 90ft | 90 |
| | DCE1038 | CrystalClear ER Cartridge Element 180ft | 180 |

| DIMENSIONS (mm) | | | | | | |
|-----------------|-----|----|-------|------|-----|--------------------------|
| Model | A | B | C | D* | E | Inlet / Outlet size (mm) |
| DCC135 | 483 | 60 | 668 | 1000 | N/A | 40/50 |
| DCC180 | | | | | | |
| DCC225 | 479 | 60 | 811.5 | 1600 | 570 | |
| DCC270 | | | 941.5 | | | |

* Minimum clearance height to remove cartridge

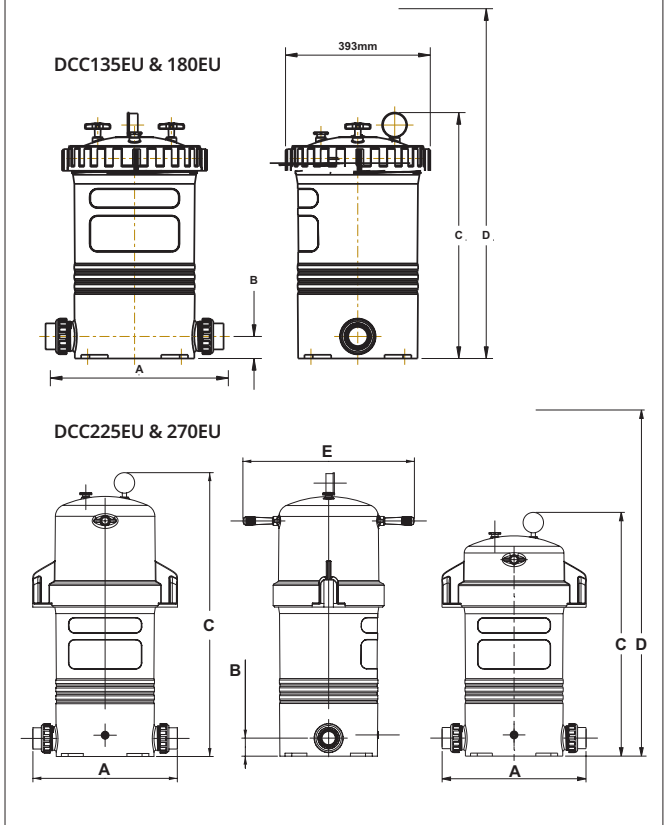

daveywater.com

This literature is not a complete guide to product usage. All images provided in this document are for illustration purposes only. Further information is available from your Davey Dealer, Davey Support Centre and from the relevant product Installation and Operating Instructions. Must be read in conjunction with the relevant product Installation and Operating Instructions and all applicable statutory requirements. Product specifications may change without notice. © Davey is a registered trademark of Davey Water Products Pty Ltd. © Davey Water Products Pty Ltd 2024.

